

Ground Movement Analysis of Pipe Roof Construction in Soft Clay

Daniel T.C. Yao & Chih-Hung Wu

Moh and Associates, Inc., 11F., No. 3, Tunhwa South Road, Section 1, Taipei 105 Taiwan

daniel.yao@maiconsultants.com & catraz.wu@maiconsultants.com

Abstract: The pipe roofing method has been widely recognized as an alternative for tunnel construction in urban areas to reduce adverse effects on underground utilities and ground surface activities. In those tunneling projects through various geological formations using pipe roofing method, the assessment of ground movement in soft clay is the most endeavoring engineering exercise. The soil behavior, pipe roof characteristics, and construction sequence have significant influence on the ground movement in the tunnel construction. In this paper, the methodology of ground movement assessment for pipe roofing method in soft clay is introduced. The key factors concerning settlement from soil behavior, pipe roof characteristics, and construction are identified. In addition, the monitoring data from the vehicle tunnel construction with pipe roofing method along the Fuhshing North Road passing through the Taipei International Airport is used for validation of this methodology.

1 INTRODUCTION

The call for tunnel construction in urban areas is often justified by minimizing the disturbance to existing underground utilities and ground surface activities. One of the most severe adverse effects from tunnel construction is excessive ground movement. Ground movement prediction is therefore particularly important in tunneling work for designers and contractors to better evaluate the risk on proposed construction technique. Piping during tunnel construction in granular formation of high groundwater levels can cause cavities in ground and potential sudden ground subsidence. In clay formation, construction disturbance usually induce excess pore pressure increase and cause strength reduction, which may result in long term ground subsidence. Both of these effects above pose significant threats to facilities in the neighborhood of tunnel construction site. The pipe roof method is designed to minimize these potential threats in tunnel construction and has been successfully used in many projects in various countries such as United States, Germany, Japan, Portugal, and Taiwan (Yao, Wu, and Chang, 2004). In all of these successful projects, the vehicle tunnel construction using pipe roof method along the Fuhshing North Road in Taiwan is the only one at such magnitude completed through soft clay formation. The Fuhshing North Road vehicle tunnel project in Taiwan will be used in this paper to illustrate the ground movement analysis process.

Unlike the forepiling method (Fig. 1), which has a long history in tunnel construction, pipe roof method constitutes a better temporary structure with respect to water tightness and structural integrity. Comparing to the traditional shield method in a short tunnel, pipe roof method has leading advantages on construction economy and flexibility of tunnel cross section (Yao *et al.*, 2004).

The detail configuration of vehicle tunnel project along the Fuhshing North Road in Taipei, Taiwan was introduced in Hsiung (1997), and Moh *et al.* (1999). The tunnel layout and profile are illustrated in Fig. 2. It is a four-lane tunnel of 592m long, approximately 22m wide, and 7.8m high under and crossing the main runways of Taipei International Airport. The pipe roof method was used in two sections, respectively, a 77m section of conventional interior braced excavation under a lawn area between work shafts C and D, and a 103.5m section between work shafts D and E directly under the runway with a width of 60m.

To further reduce the ground movement and interference of flight operation in runway area, the Endless Self Advance (ESA) method was used in junction with pipe roof method in tunnel construction of the section under runway. In this paper, the ground movement of 77m conventional braced excavation section between work shafts C and D is discussed and the monitoring data is used for the demonstration.

1.1 Pipe Roof Structure

The pipe roof structure consisted of 83 steel pipes of a uniform diameter of 0.812m and a length of 77m. The average cover above the pipe roof is approximately 5.8m in thickness. The detail configuration of pipe roof is shown on Fig. 3. The steel pipe has a wall thickness of 0.0127m and Young's modulus of 210 GPa. The exterior envelop of this pipe roof constitutes a rectangle box of 24.9m \times 10.1m \times 77m and an interior space of 23.3m \times 8.4m \times 77m. The key lock between adjacent pipes is configured to provide interlocking between pipes and proper waterproof during tunnel excavation. The pipe roof structural integrity and strength were significantly improved with these key locks and they also served as a guide for adjacent pipe during pipe jacking. The key locks were filled with waterproof sealant to form a water-tight box structure. The key lock configuration is shown on Fig. 4.

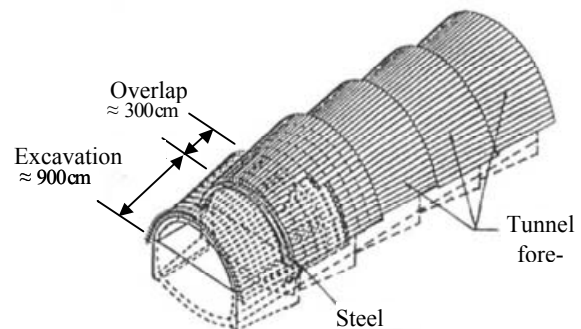

Fig. 1. Forepiling Method (After Kuo *et al.*, 1998)

1.2 Bracing System

The bracing system consisted of welding, post, ties, and corner pieces as illustrated in Fig. 5. To minimize the risk resulted from full face excavation, two levels of benched excavation with 4.7m of upper level and 3.7m of lower level were employed. The steel bracing frames were erected every 4m along the tunnel advancing direction. The bracing system was designed accordingly using mostly H beams. The temporary upper level bracing was replaced with full face bracing immediately after the excavation of lower level was completed.

1.3 Subsurface Condition

The subsurface soil condition was summarized from the geotechnical borings and laboratory test results. The boring location layout is illustrated in Fig. 6 and the boring information is shown on Fig. 7. Normally consolidated clay was encountered from ground surface to the bottom of boring with an exception of a layer of medium dense silty sand from approximately 4m to 7m below ground level. The ground water table was found at approximately the ground surface. The soil test results including the water contents, liquid limits and plasticity index, as well as unconfined compressive strengths are shown in Fig. 8.

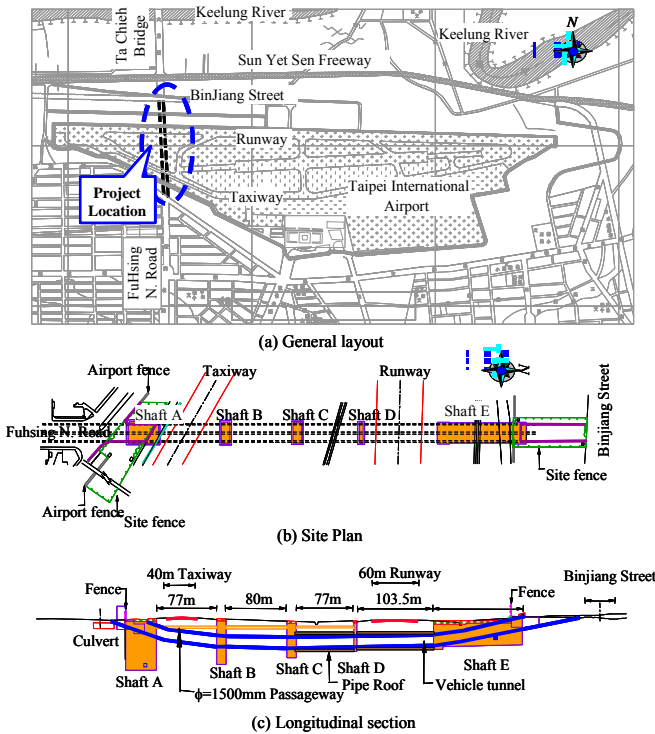

Fig. 2. Layout and Profile of Vehicle Tunnel along Fuhsing North Road

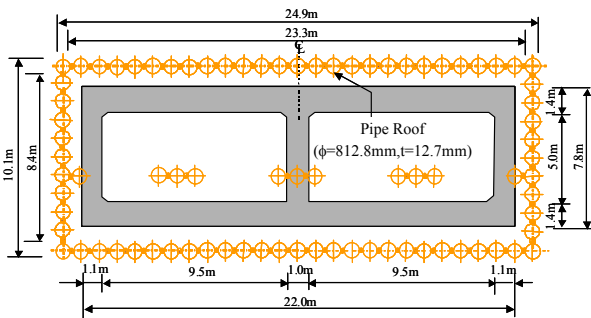

Fig. 3. Configuration of Pipe Roof

1.4 Ground Movement during Construction

The ground movement in tunnel construction is significantly affected by the subsurface conditions, construction sequence as well as quality of management, and bracing systems. In the conventional braced excavation, other factors such as the timing and workmanship of excavation and support erection can also be substantially important in pipe roof tunnel construction due to the effects of soil creep and disturbance. In addition, the excavation rate and sequence can affect the magnitudes and distribution of ground movement. Because ground movement is an irreversible process, optimization of excavation sequence can be surprisingly advantageous in minimizing the adverse effect of ground movement. An adequate numerical analysis with correct analytical model is critical in the pipe roof design.

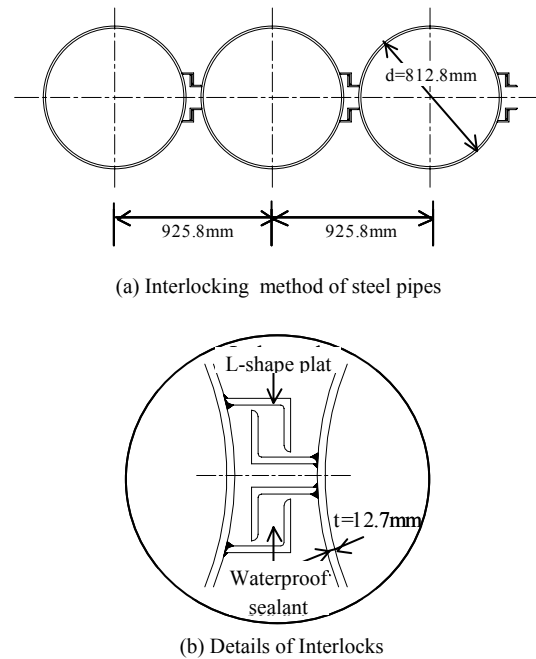

Fig. 4. Configuration of Steel Pipe Interlocking Design

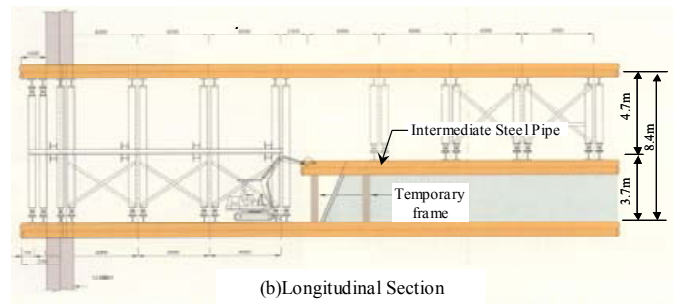
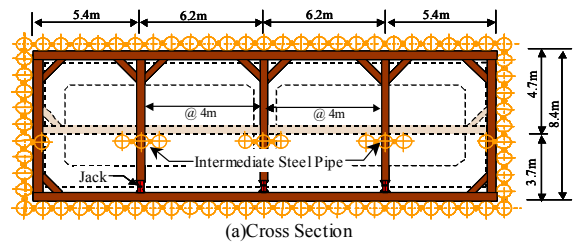

Fig. 5. Configuration of Bracing System

2 NUMERICAL SIMULATION

The soil and structure deformation is modeled using packaged commercial software FLAC (Itasca, 2000). A two-dimensional plane strain numerical model using explicit finite difference scheme with assumptions of soil isotropy and homogeneity was analyzed. Mohr-Coulomb failure criteria and linear elastic-perfectly plastic stress-strain relationship were adopted for the soil model. The effects of ground water flow and consolidation are not considered in the analysis. The temporary bracing system was simulated with beam elements and the pipe roof structure was approximated with a layer of continuum.

2.1 Material Properties

In the analysis, three major categories of material properties were assigned to, respectively: soil including natural and improved, bracing systems, and pipe roof structure. The soil strata and parameters were concluded from the geotechnical investigation result and shown in Table 1. According to a previous study (Abazovic & Pintar, 1999), the Young's moduli of cohesive soils of 400 times of undrained shear strengths were used in the analysis. In addition, Poisson's ratio of 0.49 was used for the cohesive soils since the undrained condition was assumed and the effect of consolidation was not considered. As for the granular soils, their Young's moduli were evaluated using Standard Penetration Test (SPT) N-values and a Poisson's ratio of 0.3 was adopted. The properties of beam elements as temporary bracing systems were directly obtained from the material properties, geometries, and layouts of steel H beams. For the properties of pipe roof structure, the geometries of both pipes and interlocks, properties of steel, and presumed deformation patterns were considered.

To reduce the risk and increase the safety during tunnel excavation, ground improvement was used in many areas for various purposes. The areas of ground improvement are illustrated in Fig. 9. At two ends of the tunnel, ground improvement was used to increase the soil strength for the stability of initial excavation and to decrease the permeability to avoid piping. In the silty sand layer above pipe roof, grout was used to mainly decrease the permeability and reduce the risk of piping. For the portion of silty sand enclosed in the pipe roof structure, ground improvement using horizontal double packer method was conducted to improve the strength and to reduce the permeability. To improve the stability of excavation and reduce the ground deformation, improvement of strength was carried out also with horizontal double packer method on the clay soil within the pipe roof. The unconfined compressive strength of improved clay and silty sand soils was designed to be no less than 80 kPa and had been verified with test results.

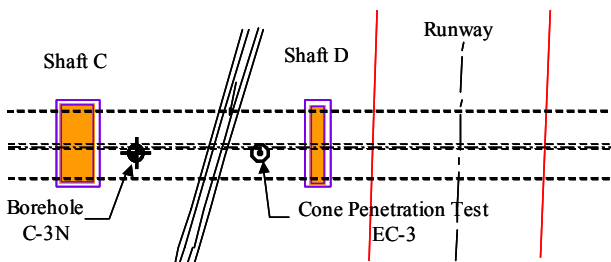

Fig. 6. Geotechnical Boring Layout

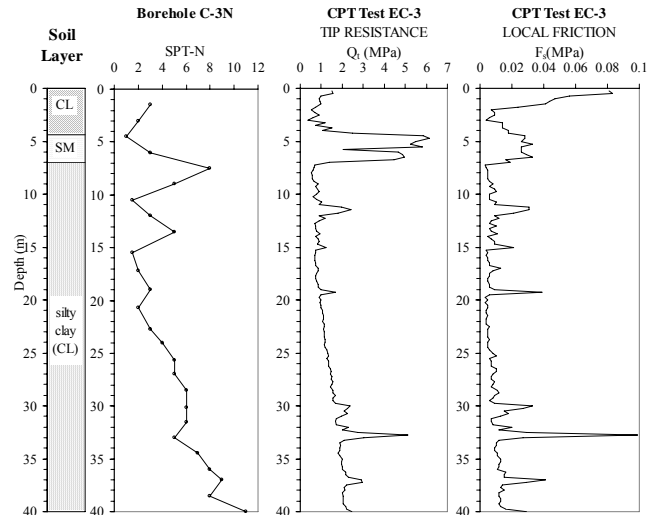

Fig. 7. Geotechnical Boring Information

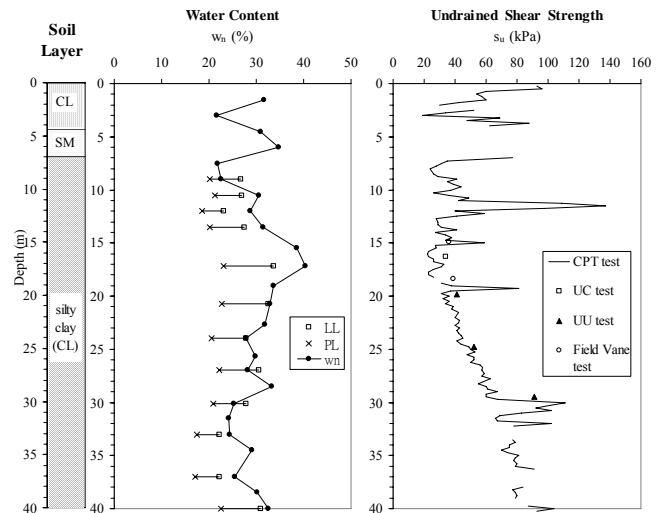

Fig. 8. Soil Test Results

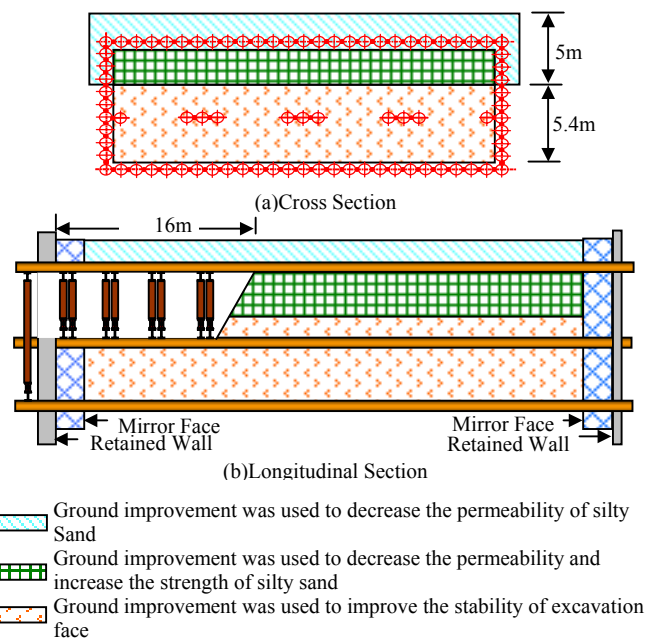

Fig. 9. Illustration of Ground Improvement Areas

2.2 Mesh Scheme and Boundary Conditions

The mesh scheme used in analysis around the tunnel was illustrated in Fig. 10 and the full mesh was extended 24m from either sides of work shafts and 37m from bottoms of work shafts to reduce boundary effects. The initial equilibrium with excavated work shafts on either sides was calculated to obtain the initial states of stress and strain before tunnel excavation. After the initial equilibrium, all the displacements were zeroed and support elements were placed at tunnel entrance before the start of excavation simulation.

2.3 Construction Sequence Simulation

After the initial equilibrium state of stress and strain was obtained and the boundary conditions were reset, the numerical simulation was executed according to the designed sequence of excavation. The soil mass within pipe roof structure was removed according to designated excavation stage as illustrated in Fig. 11. After the soil mass was removed for each designated excavation

stage, the equilibrium state of stress and strain was calculated and used as the initial condition for the next excavation stage.

Table 1. Soil Strata and Parameters

Soil Classification	Depth (m)	γ_t (kN/m ³)	ϕ' (degree)	s_u (kPa)	K_0	E (MPa)	ν
CL	4.4	18.5	30	26	0.50	10.4	0.49
SM	7.0	19.2	32	-	0.47	7.0	0.30
CL	16.2	18.6	29	28	0.52	11.2	0.49
CL	25.0	18.6	29	38	0.52	15.2	0.49
CL	35.0	19.0	30	60	0.50	24.0	0.49
CL	45.0	19.0	31	80	0.48	32.0	0.49
CL	56.0	20.0	32	128	0.47	51.2	0.49

Where ϕ' =effective friction angle; s_u = undrained shear strength; K_0 =lateral earth pressure coefficient; E=Young's modulus; ν =Poisson's ratio.

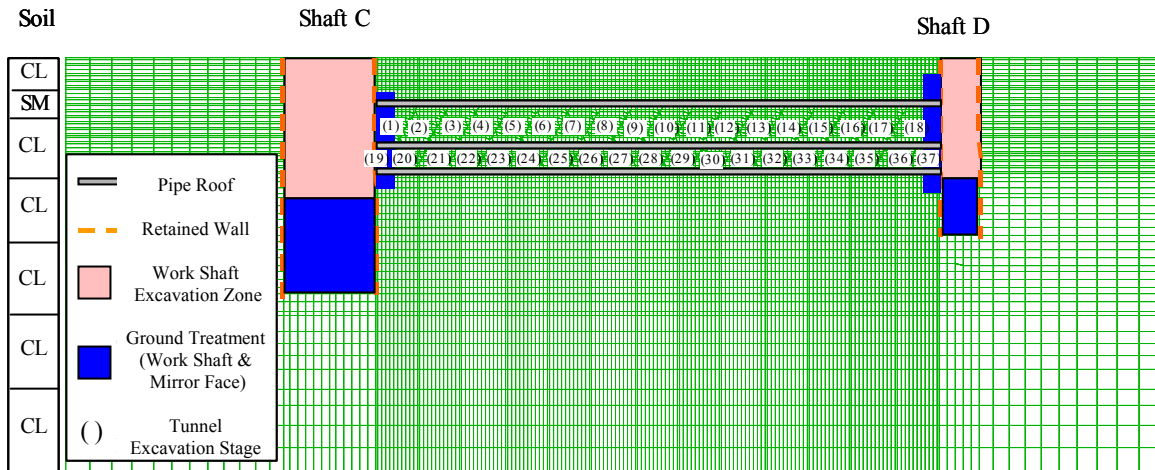

Fig. 10. Initial Mesh

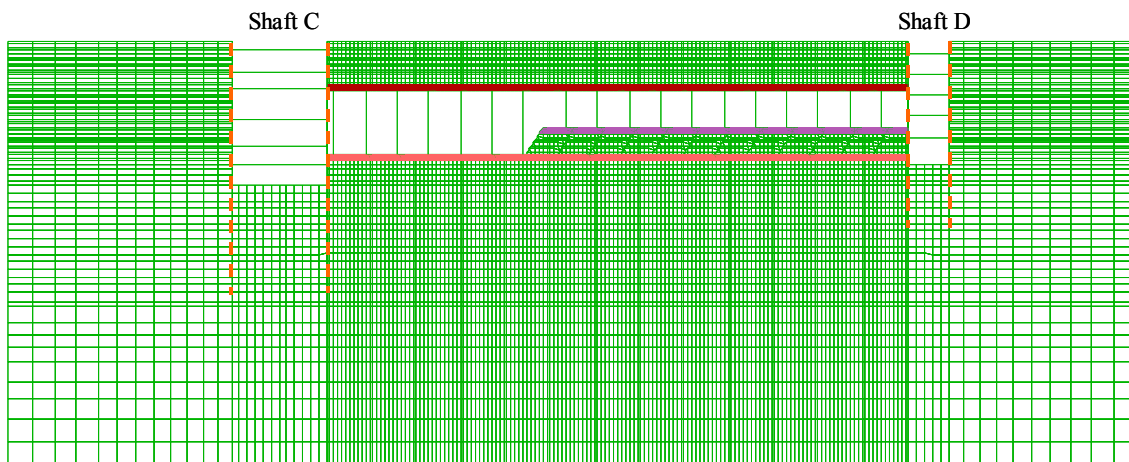

Fig. 11. Mesh at Excavation Stages

3 FIELD MONITORING PROGRAM

3.1 Instrumentation System

A comprehensive monitoring program was implemented in the field and consisted of instrumentations on loads, deformations, and pore water pressures. For the ground deformation measurements ground settlement points, horizontal inclinometers, and ground extensometers were used to collect the data. The instrumentation layout for ground deformation measurement was illustrated in Fig. 12 and the settlement measurement from the horizontal settlement meters (HSM) along the longitudinal center line in the pipe roof was presented in Fig. 13.

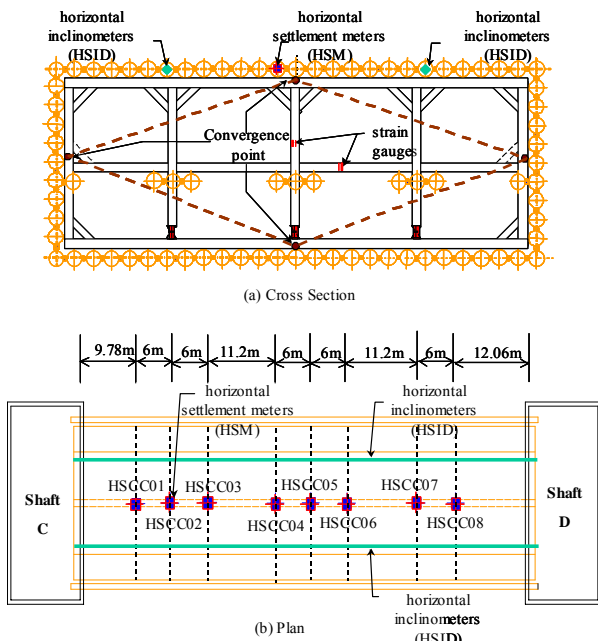

Fig. 12. Partial Instrumentation Layout

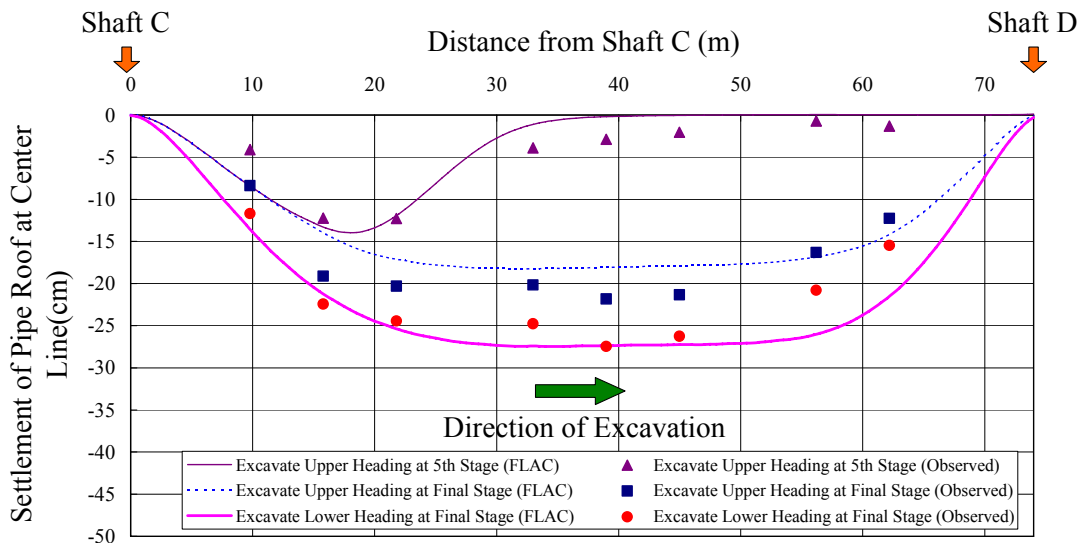

Fig. 13. Settlement Data at Center Line

3.2 Comparison of Analytical Solution and Field Data

As shown in Fig. 13, comparison between the predicted deformation and field measurement presents a satisfactory simulation result. The numerical prediction closely identifies the significance of ground movement in tunnel construction with pipe roof method. The maximum deformation was well captured in the analysis.

4 DISCUSSIONS

Disturbance of surrounding soil/rock formation was almost inevitable in tunnel construction. At this project site, cohesive soil is the dominant type of soil encompassing pipe roof tunnel. The disturbance of cohesive soils could cause pore pressure increase, and resulted in strength reduction and consolidation as a consequence of afterward pore pressure dissipation. Although the disturbance to the cohesive soil was inevitable, the structure of pipe roof had effectively reduced the influence of tunnel construction to the surrounding soil and the disturbance-induced settlement was believed to be minimal. The actual contribution of disturbance in ground deformation was yet to be determined.

Two major sources of deformations, respectively the vertical deformations of soil and pipe roof structure, could attribute to the ground settlements. In this study, an important part of pipe roof structure deformation was observed, which was the ring deflections of hollow steel pipes at the contacts of temporary welding elements as shown in Fig. 14. Even with a load redistribution plate, a concentrated load transferred from the weight of soil overburden was still applied at the crown of pipe ring as illustrated in Fig. 15. Since the geometry of pipe interlock was not designed to provide significant lateral confinement, the pipe ring will continue to deform until sufficient lateral confinement was provided by adjacent pipes or the load equilibrium was reached for each individual pipe. The load-deformation relationship was shown in Fig. 16. An independent study of ring deflection with the field approximated conditions indicated a vertical deflection of approximately 5cm on the steel pipe could occur at the intermediate pipes while the lateral confinement was not provided.

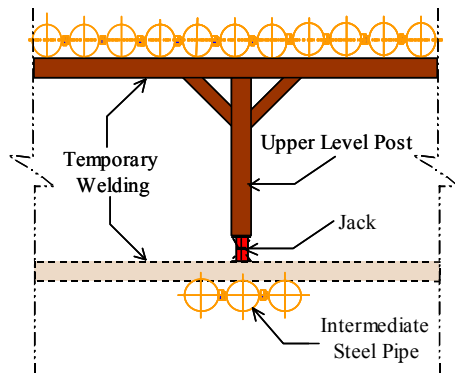

Fig. 14. Configuration of Upper Level Post Bearing System

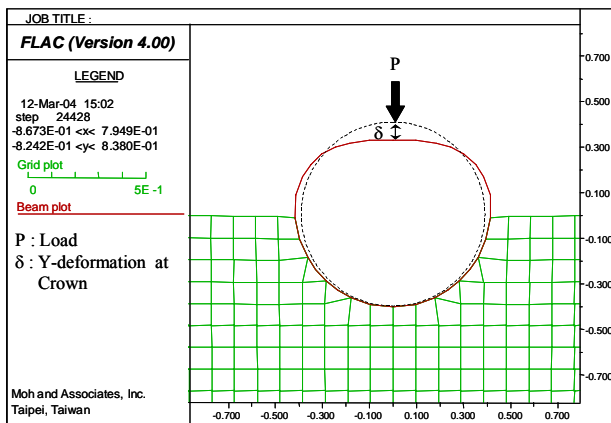

Fig. 15. Analytical Simplification

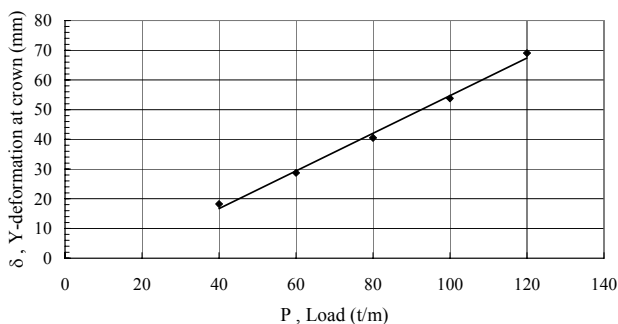

Fig. 16. The load-deformation relationship

In the numerical simulation of excavation, proper modeling of soil behavior of stress relief has often been an important and difficult issue. This difficulty results from different soil stress-strain constitutive relationships in the loading and unloading stages and the time effect of soil deformation on the construction sequence simulation. Before the soil stress-strain relation-

ship and the time effect can be properly modeled in the analysis, the common resolutions of stress relief in excavation include using partial weight elements in initial equilibrium, constrained boundary conditions, and actual lateral stress coefficients for the shallow cohesive formations.

The methodology of prediction and analysis of ground deformation in pipe roof construction using a 2-D model with an approximated plane strain condition is presented in this paper. Instead of using a costly 3-D numerical simulation, fairly consistent prediction using the 2-D model with the field measurement can provide the designer and contractor with a fast review of the design and construction process. Most of the significant features affecting ground movement including material properties and construction issues were discussed. However, several important issues such as soil disturbance, numerical difficulties, and soil constitutive modeling still require further attention.

ACKNOWLEDGMENTS

The authors are grateful to the Department of New Constructions of Taipei Municipal Government for the permission to publish this paper. Sincere appreciation is due to Dr. Za-Chieh Moh, Dr. Chung-Tien Chin, Mr. Chien-Hong Wang and Mr. Yuan-Yao Tsai for their valuable advices and to Mr. Ting-En Wu and Mr. Ching-Nan Wu for providing field data during the preparation of this manuscript.

REFERENCES

- Abazovic, E. & Pintar, G. 1999. Dimensioning and Stability Analysis of Segmental Tunnel Linings Undergoing Changes in the Stress Conditions. *FLAC and Numerical Modeling in Geomechanics*. Minnesota, USA.
- Hsiung, K.I. 1997. Design of Fushing N. Road Underpassing Taipei International Airport. *Proc., Cross-Strait Symposium on City Planning*. China. (in Chinese).
- Itasca Consulting Group Inc.. 2000. *FLAC Version 4.0, User's Manual*. Minnesota, USA.
- Kuo, C.C. & Liu, H.S. 1998. Case Study on Application of Tunnel Forepoling Method in Taiwan. *Sino-Geotechnics* 66: 25–36. (in Chinese).
- Moh, Z.C., Hsiung, K.I., Huang, P.C. & Hwang, R.N. 1999. Underpass beneath Taipei International Airport. *Proc. Conference on New Frontiers and Challenges*. Bangkok.
- Yao, D.T.C., Wu, C.-H. & Chang, Y.H. 2004. An Introduction to Design and Analysis of Pipe Roof in Soft Clay. *4th Cross Strait Seminar on Tunnel and Underground Construction*. (in Chinese).